

TAG: _____

SUBMITTAL

**3.5 Ton Split System
Heat Pump - 1 Phase
J4HP5042E1000AA**

Product Specifications

OUTDOOR UNIT	J4HP5042E1000AA
POWER CONNS. — V/PH/HZ	208/230/1/60
MIN. BRCH. CIR. AMPACITY	26.9
BR. CIR. PROT. RTG. - MAX. (AMPS)	50
COMPRESSOR	SCROLL
NO. USED - NO. SPEEDS	1 - 1
VOLTS/PH/HZ	208/230/1/60
R.L. AMPS - L.R. AMPS	8.0-112.3
FACTORY INSTALLED	
START COMPONENTS	NO
INSULATION/SOUND BLANKET	NO
COMPRESSOR HEAT	NO
OUTDOOR FAN/MOTOR	PROPELLER/ECM
DIA. (IN.) - NO. USED	23-5/8-1
TYPE DRIVE - NO. SPEEDS	EXTERNAL-10
CFM @ 0.0 IN. W.G.	3600
NO. MOTORS - HP	1 - 1/3
MOTOR SPEED R.P.M.	980
VOLTS/PH/HZ	208/230/1/60
F.L. AMPS	2.2
OUTDOOR COIL — TYPE	PLATE FIN
ROWS - F.P.I.	2 - 21
FACE AREA (SQ. FT.)	18.4
TUBE SIZE (IN.)	3/16
REFRIGERANT	
LBS. — R-410 (O.D. UNIT)	8 LBS.-7 OZ
FACTORY SUPPLIED	YES
LINE SIZE - IN. O.D. GAS	7/8
LINE SIZE - IN. O.D. LIQ.	3/8
CHARGING SPECIFICATION	
SUPERHEAT	9° F
DIMENSIONS	W X H X D
CRATED (IN.)	30-1/5×34-1/2×30-1/5
WEIGHT	
SHIPPING (LBS.)	224
NET (LBS.)	90

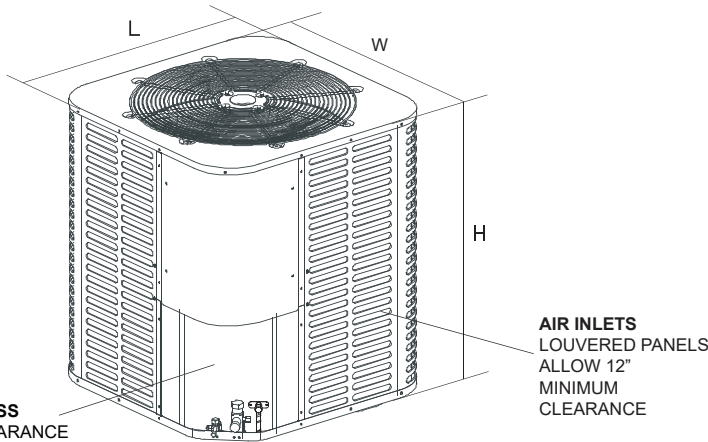

SERVICE ACCESS
ALLOW 24" CLEARANCE

AIR INLETS
LOUVERED PANELS
ALLOW 12"
MINIMUM
CLEARANCE

NOTE: GRILL APPEARANCE
MAY VARY.

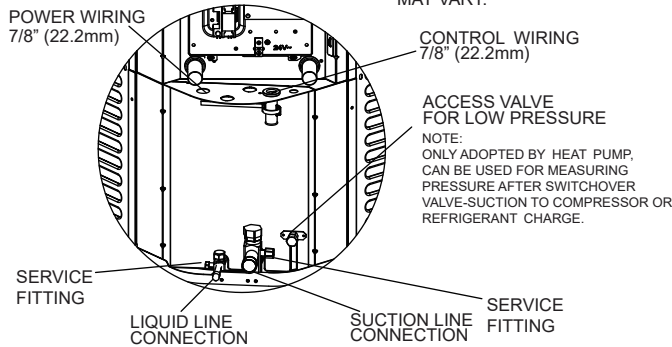

POWER WIRING
7/8" (22.2mm)

CONTROL WIRING
7/8" (22.2mm)

ACCESS VALVE
FOR LOW PRESSURE

NOTE:
ONLY ADOPTED BY HEAT PUMP.
CAN BE USED FOR MEASURING
PRESSURE AFTER SWITCHOVER
VALVE-SUCTION TO COMPRESSOR OR
REFRIGERANT CHARGE.

SERVICE
FITTING

LIQUID LINE
CONNECTION

SUCTION LINE
CONNECTION

SERVICE
FITTING

NOTE: All dimensions are in mm/inches.

Model	H	W	L	LIQUID VALVE SIZE	GAS VALVE SIZE
J4HP5042E1000AA	843(33-3/16)	740(29-1/8)	740(29-1/8)	3/8	7/8

Mechanical Specification Options

General

The J4HP50 is fully charged from the factory. This unit is designed to operate at outdoor ambient temperatures as high as 115°F. Cooling capacities are matched with air handlers and furnace coils that are AHRI certified. The unit is certified to ETL. Exterior is designed for outdoor application.

Casing

Unit casing is constructed of heavy gauge, Galvanized steel and painted with a weather-resistant powder paint on all grilles, panels, pre-paint on all other panels. And had 500-hours salt spray tested.

Refrigerant Controls

Refrigeration system controls include condenserfan, compressor contactor.

Compressor

Features include low vibration and noise.

Condenser Coil

The outdoor coil provides low airflow resistance and efficient heat transfer. The coil is protected on all four sides by grille panels.

Optional accessories

Liquid line drier —

It is used to filter out impurities and water in the system, ensures system clean and dry.



OXBOX has a policy of continuous product and product data improvement and it reserves the right to change design and specifications without notice.

BX-PRQ-J4HP5042E1000A-1A